

## **Bandsaw Safety**

1. Keep hands to the side of the blade, away from the path of the blade.
2. If the blade breaks, step aside and disconnect the electricity to the machine.
3. Keep your fingers at least 2 inches from the blade at all times. Use a fixture to hold small pieces.
4. Always keep the upper guide assembly 1/4 to 1/2 inch above the stock. This prevents an excess amount of the blade from being exposed.
5. Push the stock forward rather than to the side.
6. Work within the capacity of the saw. A thick piece of stock must be fed slower into the blade than a thin piece.
7. Observe the safety zone around the band saw. If the blade breaks, it will occasionally “climb” out to the right side of the operator.

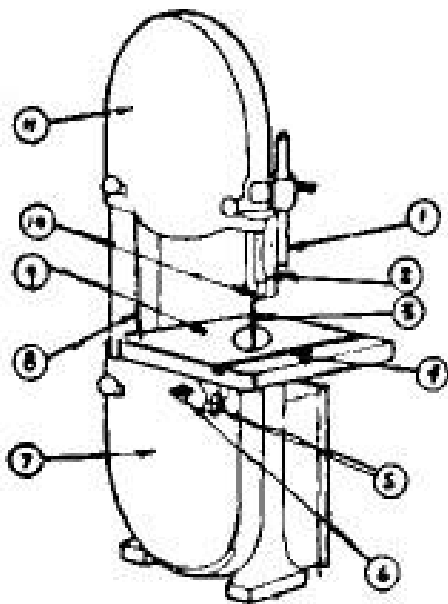

1. Guide post
2. Blade Support Lock Screw
3. Blade
4. Miter Gauge Groove
5. Table Clamp
6. Adjusting Screw for Blade Guides
7. Lower Wheel Guard
8. Rear Blade Guard
9. Table
10. Upper Blade Guard
11. Upper Wheel Guard