

Planer Safety

1. When using the planer, never surface a piece of stock shorter than the recommended minimum length. Consult the instructor or operation manual if this information is not posted on the machine. The minimum length of stock to be used for most planers is 12 to 16 inches.
2. Hold the stock in a horizontal position and with both hands as it is fed into the planer.
3. Feed stock so the planer knives cut with the grain.
4. Wide stock and hardwood stock should be fed at slow speeds. The depth of cut should also be reduced.
5. Inspect the stock for defects. Make certain the stock does not contain any nails or paint, and that it is warp-free.
6. Never look into the mouth of the planer while it is running. If stock gets caught or turns sideways, stop the machine before lowering the table. Then remove the jammed material.

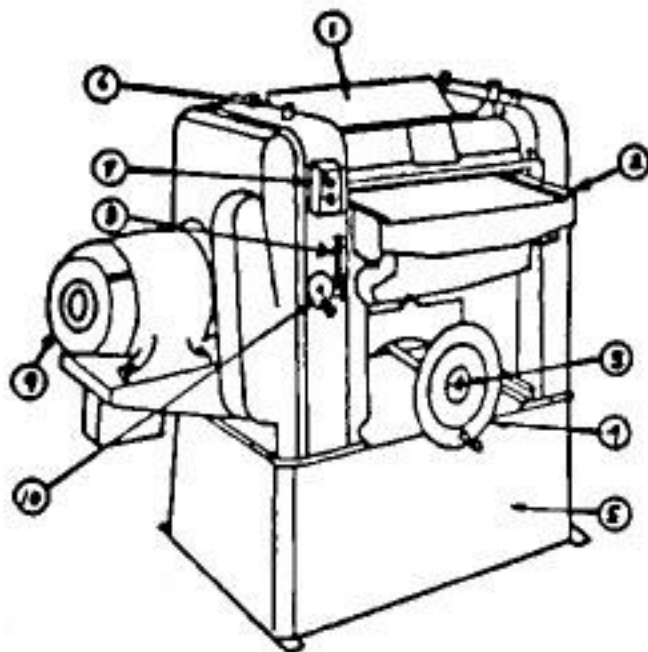

1. Chip Guard
2. Table
3. Hand Wheel Lock
4. Elevating Hand Wheel
5. Base
6. Feed Roll Adjustments
7. Switch
8. Depth- of- Cut Gauge
9. Motor
10. Variable Speed Feed Roll